

SENSITIVITY OF THE RESPONSE OF MODERATELY THICK CROSS-PLY DOUBLY-CURVED PANELS TO LAMINATION AND BOUNDARY CONSTRAINT—I. THEORY

REAZ A. CHAUDHURI and HUMAYUN R. H. KABIR†

Department of Civil Engineering, University of Utah, 3220 Merrill Engineering Building,
Salt Lake City, UT 84112 U.S.A.

(Received 26 February 1991; in revised form 10 June 1992)

Abstract—Hitherto unavailable analytical solutions to the boundary-value problem of moderately thick general cross-ply laminated doubly-curved panels of rectangular planform, subjected to various boundary conditions, are presented. The five highly coupled second-order linear partial differential equations, that characterize the deformation of such laminates are solved in Part I of the paper using a recently developed double Fourier series based approach, together with the SS1-, SS2- and SS4-types of simply-supported and C4-type of clamped boundary conditions prescribed at all four edges. The issues of derivation of the linear algebraic equations arising from these boundary conditions, together with an efficient method of solving the complete system of linear algebraic equations, convergence characteristics and other numerical results are addressed in the accompanying Part II of this investigation.

1. INTRODUCTION

Curved panels (open shells) are common load-bearing structural elements in aerospace, hydrospace, nuclear and other industrial applications. Recent years have witnessed an increasing use of advanced composite materials (e.g. graphite/epoxy, boron/epoxy, Kevlar/epoxy, graphite/PEEK, etc.) which are replacing metallic alloys in the fabrication of such panels because of such beneficial properties as higher strength-to-weight ratios, longer fatigue (including sonic fatigue) life, better stealth characteristics, enhanced corrosion resistance, and, most significantly, the possibility of optimal design through the variation of stacking pattern, fiber orientation, and so forth, known as composite tailoring. The advantages that accrue from these properties are, however, not attainable without paying for the complexities that are introduced by various coupling effects, first studied by Ambartsumyan (1953). Furthermore, since the matrix material is of relatively low shearing stiffness as compared to the fibers, a reliable prediction of the response of these laminated shells must account for transverse shear deformation. Additionally, a solution to the problem of the deformation of laminated shells and panels of finite dimensions must satisfy the boundary conditions, which introduce additional complexities into the analysis.

The majority of the investigations on cross-ply shells and panels utilize either the classical lamination theory (CLT), which corresponds to the Love–Kirchhoff hypothesis (Love’s first approximation theory) for homogeneous shells, or the first-order shear deformation theory (FSDT), based on the Reissner–Mindlin hypothesis. Stavsky and Lowey (1971), Jones and Morgan (1975) and Greenberg and Stavsky (1980) have all used the CLT in obtaining analytical solutions for the vibration and buckling of cross-ply cylindrical shells. Soldatos and Tzivanidis (1982) have presented CLT-based analytical solutions for the vibration and buckling of cross-ply cylindrical panels. Jones and Morgan (1975) and Soldatos and Tzivanidis (1982) have used Donnell’s (1933) kinematic relations, while Stavsky and Lowey (1971) and Greenberg and Stavsky (1980) have used a Love (1927)-type theory. Soldatos (1984a) has presented a comparison of the fundamental frequency, computed using four popular thin shell theories, namely those due to Donnell, Love, Sanders and Flugge. Soldatos (1984b) has also used a second-approximation Flugge-type theory and has presented results for the vibration of cross-ply oval (cylindrical) shells, using the

† Current address: EMRC, Troy, MI 48083, U.S.A.

approximate method of Galerkin. Iu and Chia (1988), in extending Chia's (e.g. 1980) earlier studies on plates, have resorted to Galerkin's method [because the governing partial differential equation (PDE) is not satisfied by the assumed beam functions, involving hyperbolic sine and hyperbolic cosine] to obtain an approximate solution to the problem of nonlinear vibration and postbuckling of thin unsymmetric cross-ply circular cylindrical shells. Dong and Tso (1972) have developed a FSDT-based theory for cross-ply shells and presented analytical solutions for the vibration of complete cylindrical shells. Sinha and Rath (1976) have utilized FSDT in conjunction with Donnell's (1933) kinematic relations to obtain an analytical solution to the problem of a circular cylindrical panel under transverse loading. Bert and Kumar (1982) have obtained analytical solutions to the problem of vibration of bimodulus two-layer cross-ply thin cylindrical shells, using four tracers to handle four popular theories, namely Sanders' (1959), Love's (1927), Morley's (1959) and Donnell's (1933).

An indepth analysis of the literature reveals that although CLT-based analytical solutions for rectangular cross-ply plates are available for various boundary conditions [e.g. Whitney (1970) and Whitney and Leissa (1970)], including the clamped one, their FSDT-based counterparts for curved panels (open shells) appear to be, in general, limited to Navier- or Levy-type (including generalized Levy-type) solutions, where a specific type of simply-supported boundary condition [designated SS3 by Hoff and Rehfield (1965)] needs to be prescribed at either all four edges (Navier's method) or two opposite edges (Levy's approach). Examples of the former include double Fourier series solutions (Sinha and Rath, 1976), for cross-ply cylindrical panels with the SS3-type simply-supported boundary conditions prescribed at all four edges, while the generalized Levy-type solution by Librescu *et al.* (1989) and Khdeir *et al.* (1989) to the problem of a doubly-curved panel with two opposite edges being invariably simply supported of the SS3-type, belong to the latter category. Although a preliminary FSDT-based analysis of cross-ply doubly-curved panels, with the SS2-type simply-supported boundary conditions were presented by the authors (1987), it is the authors' belief that a comprehensive and indepth treatment of the subject, especially with other types of boundary conditions, e.g. all edges clamped, is still nonexistent in the published literature. The primary objective of the present study is to bridge this longstanding analytical gap.

Recently, Chaudhuri (1987, 1989) has presented a novel double Fourier series approach for solution of a system of highly coupled linear PDEs with constant coefficients, satisfying Dirichlet, Neumann, or arbitrary (mixed) boundary conditions. Although the boundary-discontinuous Fourier series method has been applied by such earlier investigators as Goldstein (1936, 1937), Green (1944), Green and Hearmon (1945), Winslow (1951), Whitney (1970, 1971) and Whitney and Leissa (1970), the criteria determining when the boundary Fourier series are needed or not needed, have never been clearly explained. A clear exposition of this important topic is available in Chaudhuri (1989). The domain of the problem is of rectangular planform. The five highly coupled second-order linear partial differential equations, that characterize the deformation of doubly-curved cross-ply panels, will be solved in Part I of this paper, using this approach (Chaudhuri, 1989), together with the SS1-, SS2- and SS4-type simply-supported and C4-type clamped boundary conditions prescribed at all four edges. The issues of derivation of the linear algebraic equations arising from boundary conditions, together with an efficient method of solving the complete system of linear algebraic equations, convergence characteristics and other numerical results are addressed in the accompanying Part II of this investigation.

2. STATEMENT OF THE PROBLEM

Figure 1 shows the geometry of the doubly-curved cross-ply panel under consideration. x_1 and x_2 are the lines of curvature of the middle (reference) surface, $x_3 = 0$. The x_3 coordinate is normal to the mid-surface such that x_1, x_2, x_3 form a right-handed orthogonal curvilinear coordinate system. The principal radii of curvature of the mid-surface are R_1 and R_2 in the x_1 and x_2 directions, respectively. The analysis that follows is based on the assumptions of (i) shallowness, (ii) transverse inextensibility, (iii) first-order shear

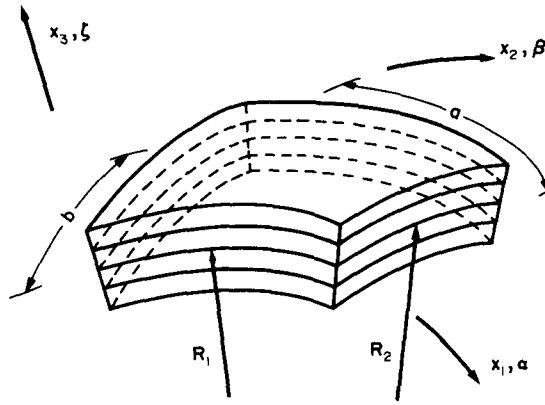

Fig. 1. A doubly-curved panel of rectangular planform.

deformation theory (FSDT), and (iv) negligibility of geodesic curvatures of the surface-parallel lines of curvature coordinates. Under these hypotheses, the kinematic relations are given by

$$\varepsilon_1 = \varepsilon_1^0 + x_3 \kappa_1, \quad \varepsilon_2 = \varepsilon_2^0 + x_3 \kappa_2, \quad \varepsilon_4 = \varepsilon_4^0, \quad \varepsilon_5 = \varepsilon_5^0, \quad \varepsilon_6 = \varepsilon_6^0 + x_3 \kappa_6, \quad (1)$$

in which ε_i and ε_i^0 , $i = 1, 2, 6$, represent the surface-parallel normal and shearing strain components at a parallel surface and mid-surface, respectively, while ε_i , ε_i^0 ($i = 4, 5$) represent the corresponding transverse shearing strain components. κ_i ($i = 1, 2, 6$) denote the changes of curvature and twist.

$$\begin{aligned} \varepsilon_1^0 &= u_{1,1} + u_3/R_1, & \varepsilon_2^0 &= u_{2,2} + u_3/R_2, & \varepsilon_4^0 &= u_{3,2} + \phi_2 - u_2/R_2, \\ \varepsilon_5^0 &= u_{3,1} + \phi_1 - u_1/R_1, & \varepsilon_6^0 &= u_{1,2} + u_{2,1}, & \kappa_1 &= \phi_{1,1}, \\ \kappa_2 &= \phi_{2,2}, & \kappa_6 &= \phi_{2,1} + \phi_{1,2} + c(u_{1,2} - u_{2,1}), \end{aligned} \quad (2)$$

in which c denotes the constant

$$c = \frac{1}{2} \left(\frac{1}{R_1} - \frac{1}{R_2} \right) \quad (3)$$

and a comma denotes partial differentiation. u_i ($i = 1, 2, 3$) and ϕ_i ($i = 1, 2$) denote the displacement and rotation respectively in the i th direction. The equations of equilibrium, using Sanders' (1959) shell theory are given by

$$\begin{aligned} N_{1,1} + N_{6,2} + cM_{6,2} + Q_1/R_1 &= 0, & Q_{1,1} + Q_{2,2} - N_1/R_1 - N_2/R_2 + q &= 0, \\ N_{6,1} - cM_{6,1} + N_{2,2} + Q_2/R_2 &= 0, & M_{1,1} + M_{6,2} - Q_1 &= 0, & M_{6,1} + M_{2,2} - Q_2 &= 0. \end{aligned} \quad (4)$$

Equations (1)–(4) can be specialized to flat plates, cylindrical shells and spherical shells, by setting $1/R_1 = 1/R_2 = 0$, $1/R_1 = 0$, $R_2 = R$ and $R_1 = R_2 = R$, respectively. For a general cross-ply shell (Jones and Morgan, 1975), surface-parallel stress resultants, N_i , stress couples (moment resultants) M_i , and transverse shear stress resultants, Q_i , are related to the mid-surface strains, ε_i^0 , and changes of curvature and twist, κ_i , by

$$\begin{aligned} N_i &= A_{ij} \varepsilon_j^0 + B_{ij} \kappa_j, & (i, j = 1, 2), & & N_6 &= A_{66} \varepsilon_6^0 + B_{66} \kappa_6, \\ M_i &= B_{ij} \varepsilon_j^0 + D_{ij} \kappa_j, & (i, j = 1, 2), & & M_6 &= B_{66} \kappa_6 + D_{66} \kappa_6, \\ Q_1 &= A_{55} \varepsilon_5^0, & & & Q_2 &= A_{44} \varepsilon_4^0, \\ A_{55} &= K_1^2 A'_{55}, & & & A_{44} &= K_2^2 A'_{44}. \end{aligned} \quad (5)$$

Here A_{ij} , B_{ij} , D_{ij} , $i, j = 1, 2, 6$, are extensional, coupling and bending rigidities respectively, and A'_{ii} (no sum, $i = 4, 5$) represent transverse shear rigidities. It may be noted that the above quantities refer to cross-ply properties following the lines of curvature of the shell. K_i^2 , $i = 1, 2$, represent the shear correction factors.

Substitution of eqns (2), (5) into eqn (4) yields five coupled PDEs with constant coefficients, which can be written in the matrix operator form:

$$\mathbf{L}\mathbf{v} = \mathbf{f}, \quad (6)$$

where

$$L_{ij} = L_{ji}, \quad i, j = 1, \dots, 5, \quad \mathbf{v}^T = \{u_1, u_2, u_3, \phi_1, \phi_2\} \quad \text{and} \quad \mathbf{f}^T = \{0, 0, q, 0, 0\}. \quad (7)$$

Denoting

$$\frac{\partial}{\partial x_1} = \partial_1, \quad \frac{\partial^2}{\partial x_1^2} = \partial_1^2, \quad \frac{\partial}{\partial x_2} = \partial_2, \quad \frac{\partial^2}{\partial x_2^2} = \partial_2^2, \quad \frac{\partial^2}{\partial x_1 \partial x_2} = \partial_1 \partial_2,$$

the elements of \mathbf{L} can be written as follows:

$$\begin{aligned} L_{11} &= G(1, 1) + G(1, 2) \partial_1^2 + G(1, 3) \partial_2^2, & L_{12} &= G(1, 4) \partial_1 \partial_2, & L_{13} &= G(1, 5), \\ L_{14} &= G(1, 6) + G(1, 7) \partial_1^2 + G(1, 8) \partial_2^2, & L_{15} &= G(1, 9) \partial_1 \partial_2, \\ L_{22} &= G(2, 2) + G(2, 3) \partial_1^2 + G(2, 4) \partial_2^2, & L_{23} &= G(2, 5) \partial_2, & L_{24} &= G(2, 6) \partial_1 \partial_2, \\ L_{25} &= G(2, 7) + G(2, 8) \partial_1^2 + G(2, 9) \partial_2^2, & L_{33} &= G(3, 3) + G(3, 4) \partial_1^2 + G(3, 5) \partial_2^2, \\ L_{34} &= G(3, 6) \partial_1, & L_{35} &= G(3, 7) \partial_2, & L_{44} &= G(4, 6) + G(4, 7) \partial_1^2 + G(4, 8) \partial_2^2, \\ L_{45} &= G(4, 9) \partial_1 \partial_2, & L_{55} &= G(5, 7) + G(5, 8) \partial_1^2 + G(5, 9) \partial_2^2, \end{aligned} \quad (8)$$

where the nonzero constants $G(i, j)$, $i = 1, \dots, 5$, $j = 1, 2, 3, \dots$ are as defined in eqns (A11) of Appendix C. The five boundary conditions at an edge, $x_n = \text{constant}$, are chosen to be one member from each pair of

$$(u_n, N_n) = (u_t, N_t) = (u_3, Q_n) = (\phi_n, M_n) = (\phi_t, M_t) = 0, \quad (9)$$

where subscripts n and t denote normal and tangential directions to an edge. For example, at an edge, $x_1 = \text{constant}$, u_n , u_t , ϕ_n , ϕ_t , N_n , N_t , M_n , M_t and Q_n correspond to u_1 , u_2 , ϕ_1 , ϕ_2 , N_1 , N_6 , M_1 , M_6 and Q_1 , respectively. The various simply-supported and clamped boundary conditions at an edge, $x_n = \text{constant}$, may be listed as follows (Hoff and Rehfield, 1965; Chaudhuri and Abu-Arja, 1988, 1989):

$$(\text{SS1, C1}): \quad N_n = N_t = u_3 = (M_n, \phi_n) = \phi_t = 0, \quad (10a)$$

$$(\text{SS2, C2}): \quad u_n = N_t = u_3 = (M_n, \phi_n) = \phi_t = 0, \quad (10b)$$

$$(\text{SS3, C3}): \quad N_n = u_t = u_3 = (M_n, \phi_n) = \phi_t = 0, \quad (10c)$$

$$(\text{SS4, C4}): \quad u_n = u_t = u_3 = (M_n, \phi_n) = \phi_t = 0. \quad (10d)$$

3. METHOD OF SOLUTION

The present solution strategy is based on a recently developed double Fourier series approach (Chaudhuri, 1989) for the solution of a system of highly coupled PDEs with constant coefficients, subjected to Dirichlet, Neumann or mixed boundary conditions. This

method facilitates the well-posedness of the Fourier analysis through selection of the coefficients of the assumed double Fourier series solutions for the unknown functions and introduction of certain boundary-discontinuous Fourier coefficients, so that the number of equations becomes equal to the number of unknown coefficients to furnish a complete solution. The presence of discontinuities of the assumed solution functions or their first derivatives at the boundaries, which yield additional unknown coefficients, is handled by utilizing a mathematical approach, discussed by Hobson (1926) and utilized by Goldstein (1936, 1937) in the context of the direct use of ordinary Fourier series to solve the stability of fluid flow. Green (1944) can be credited with the first direct use of double Fourier series for solution to the problem of a clamped isotropic plate. Winslow (1951), following Hobson's (1926) lead, has discussed the mathematical conditions of differentiation, of stress functions and their partial derivatives represented by ordinary Fourier series, in the presence of "ordinary" [in the sense of Hobson (1926)] discontinuities and has concluded that unless additional conditions imposed by termwise differentiation are fulfilled, the hypothetical representation by Fourier series may not have sufficient generality to satisfy all the required conditions and furnish a solution.

Green and Hearmon (1945) and Whitney (1971) have extended the double Fourier series approach of Green (1944) to solve the problems of symmetrically laminated thin anisotropic plates with simply-supported and clamped boundary conditions, respectively. Whitney (1970) appears to be the first to apply this technique to the analysis of thin unsymmetric cross-ply plates. Whitney and Leissa (1970) have obtained analytical solutions to the problems of antisymmetric cross-ply and angle-ply thin plates, subjected to SS1 boundary conditions, using the same double Fourier series approach, which may be regarded as an extension of the work of Green (1944) and Winslow (1951). A problem of the type studied by Green (1944), Green and Hearmon (1945), and Whitney (1971) is characterized by one fourth-order PDE in one unknown—the transverse displacement, u_3 , while the type studied by Whitney and Leissa (1970) is characterized by two coupled fourth-order PDEs in two unknown quantities—the transverse displacement, u_3 , and inplane stress function, ϕ . In contrast, the problem of a thin unsymmetric cross-ply plate, studied by Whitney (1970), is characterized by three coupled PDEs in three unknown mid-surface displacements, u_1, u_2, u_3 , while the present problem is mathematically represented by five highly coupled second-order PDEs in five unknown displacement and rotations, namely, u_1, u_2, u_3, ϕ_1 and ϕ_2 .

The solution is assumed to be as follows :

$$\begin{aligned} (u_1(x_1, x_2); \phi_1(x_1, x_2)) &= \sum_{m=0}^{\infty} \sum_{n=1}^{\infty} (U_{mn}; x_{mn}) \cos(\alpha_m x_1) \sin(\beta_n x_2), \\ (u_2(x_1, x_2); \phi_2(x_1, x_2)) &= \sum_{m=1}^{\infty} \sum_{n=0}^{\infty} (V_{mn}; Y_{mn}) \sin(\alpha_m x_1) \cos(\beta_n x_2), \\ u_3(x_1, x_2) &= \sum_{m=1}^{\infty} \sum_{n=1}^{\infty} W_{mn} \sin(\alpha_m x_1) \sin(\beta_n x_2), \end{aligned} \quad (11)$$

where

$$\alpha_m = m\pi/a, \quad \beta_n = n\pi/b. \quad (12)$$

If an assumed solution function fails to satisfy a prescribed geometric boundary condition at an edge, then it is forced to satisfy this boundary condition at that edge. However, "ordinary" discontinuities may still arise in (i) the first derivatives, of the same function, at that edge, (ii) the same function and/or its first derivatives at other edges, and (iii) other functions and/or their first derivatives. The corresponding first or second derivatives are then obtained by expanding them in double Fourier series in the form suggested by, e.g., Hobson (1926), Goldstein (1936, 1937), Green (1944), Green and Hearmon (1945), Winslow (1951), Whitney (1970, 1971), Whitney and Leissa (1970), Chaudhuri (1987, 1989) and Chaudhuri and Abu-Arja (1988), wherein "ordinary" discontinuities are accounted for.

This procedure will be illustrated in the cases of SS1, SS2, SS4 and C4 boundary conditions, prescribed at all the four edges. Solutions for the remaining cases can be obtained following a similar approach and are omitted in the interest of brevity of presentation.

SS1 boundary conditions

In this case, all the first and second derivatives of u_3 can be obtained by term-by-term differentiation. However, the same is not true for the remaining functions, because some physical conditions are violated by some of these functions and/or their derivatives at some or all of the edges. The procedure is illustrated for the assumed solution function $u_1(x_1, x_2)$, given by

$$u_1(x_1, x_2) = \sum_{m=0}^{\infty} \sum_{n=1}^{\infty} U_{mn} \cos(\alpha_m x_1) \sin(\beta_n x_2), \quad 0 \leq x_1 \leq a, 0 < x_2 < b, \quad (13a)$$

as follows:

The two first partial derivatives follow directly from eqns (A2b, c), (A6) and (A9) and can be written as

$$u_{1,1}(x_1, x_2) = - \sum_{m=1}^{\infty} \sum_{n=1}^{\infty} U_{mn} \alpha_m \sin(\alpha_m x_1) \sin(\beta_n x_2), \quad 0 < x_1 < a, 0 < x_2 < b, \quad (13b)$$

$$u_{1,2}(x_1, x_2) = \frac{1}{4} a_0 + \frac{1}{2} \sum_{m=1}^{\infty} a_m \cos(\alpha_m x_1) + \frac{1}{2} \sum_{n=1}^{\infty} [\beta_n U_{0n} + \gamma_n a_0 + \psi_n b_0] \cos(\beta_n x_2) \\ + \sum_{m=1}^{\infty} \sum_{n=1}^{\infty} [\beta_n U_{mn} + \gamma_n a_m + \psi_n b_m] \cos(\alpha_m x_1) \cos(\beta_n x_2), \quad (13c)$$

in which

$$(\gamma_m, \psi_m) = \begin{cases} (0, 1) & \text{if } m \text{ is odd,} \\ (1, 0) & \text{if } m \text{ is even.} \end{cases} \quad (14)$$

Extension of the above to the second derivatives is straightforward [see Chaudhuri (1989)], e.g.

$$u_{1,11}(x_1, x_2) = \frac{1}{2} \sum_{n=1}^{\infty} c_n \sin(\beta_n x_2) + \sum_{m=1}^{\infty} \sum_{n=1}^{\infty} [-\alpha_m^2 U_{mn} + \gamma_m c_n + \psi_m d_n] \cos(\alpha_m x_1) \sin(\beta_n x_2). \quad (15)$$

The constant coefficients a_m, b_m, c_n, d_n in eqns (13c), (15) are as defined in eqns (B1a, b) in Appendix B. Derivatives of other functions (u_2, ϕ_1 and ϕ_2) can be obtained in a manner similar to the procedure adopted for the derivatives of u_1 as shown in eqns (13c), (15). This procedure, when applied to the other assumed functions, leads to four more pairs of constant coefficients, defined by eqns (B1c-f): the two pairs, $(e_n, f_n), (i_n, j_n)$ for each n , being associated with u_2 and $\phi_{1,1}$, respectively along the boundaries $x_1 = 0, a$; while the remaining two pairs, $(g_m, h_m), (k_m, l_m)$ for each m , being associated with $u_{2,2}$ and $\phi_{2,2}$ respectively along the boundaries $x_2 = 0, b$.

Expansion of the transverse loads $q(x_1, x_2)$ into double Fourier series

$$q(x_1, x_2) = \sum_{m=1}^{\infty} \sum_{n=1}^{\infty} q_{mn} \sin(\alpha_m x_1) \sin(\beta_n x_2), \quad (16)$$

and substitution of the assumed functions and their derivatives into eqns (6)–(8) finally yield, on equating the coefficients of $\cos(\alpha_m x_1) \sin(\beta_n x_2), \sin(\alpha_m x_1) \cos(\beta_n x_2),$ etc., $5mn + 2m + 2n$ simultaneous linear algebraic equations. In the interest of brevity, the procedure is illustrated

only for the first and third of the five equilibrium equations (6)–(8), which yield the following:

$$\begin{aligned}
 & [G(1, 1) - G(1, 2)\alpha_m^2 - G(1, 3)\beta_n^2]U_{mn} - G(1, 4)\alpha_m\beta_n V_{mn} + G(1, 5)\alpha_m W_{mn} \\
 & + [G(1, 6) - G(1, 7)\alpha_m^2 - G(1, 8)\beta_n^2]X_{mn} - G(1, 9)\alpha_m\beta_n Y_{mn} - G(1, 3)\beta_n\gamma_n a_m \\
 & - G(1, 3)\beta_m\psi_n b_m + G(1, 2)\gamma_m c_n + G(1, 2)\psi_m d_n - G(1, 4)\beta_n\gamma_m e_n - G(1, 4)\beta_n\psi_m f_n \\
 & + G(1, 7)\gamma_m i_n + G(1, 7)\psi_m j_n = 0, \quad (17a)
 \end{aligned}$$

$$\begin{aligned}
 & [G(1, 1) - \frac{1}{2}G(1, 3)\beta_n^2]U_{0n} + [G(1, 6) - G(1, 8)\beta_n^2]X_{0n} - \frac{1}{2}G(1, 3)\beta_n\gamma_n a_0 \\
 & - \frac{1}{2}G(1, 3)\beta_n\psi_n b_0 + \frac{1}{2}G(1, 2)c_n - \frac{1}{2}G(1, 4)\beta_n e_0 + \frac{1}{2}G(1, 7)i_n = 0, \quad (17b)
 \end{aligned}$$

$$\begin{aligned}
 & -G(3, 1)\alpha_m U_{mn} - G(3, 2)\beta_n V_{mn} + [G(3, 3) - G(3, 4)\alpha_m^2 - G(3, 5)\beta_n^2]W_{mn} - G(3, 6)\alpha_m X_{mn} \\
 & - G(3, 7)\beta_n V_{mn} = q_{mn}. \quad (17c)
 \end{aligned}$$

SS2 boundary conditions

As in the preceding case, the first and second partial derivatives of the assumed displacement function u_3 can be obtained by term-by-term differentiation. Discontinuities in the remaining assumed displacement functions and their derivatives are manipulated in a manner similar to the SS1 boundary condition, resulting in an identical number of total unknown constant coefficients. The governing partial differential equations (6)–(8) supply a set of $5mn + 2m + 2n$ linear algebraic equations, similar, in nature, to their SS1 counterparts.

SS4 boundary conditions

In this case, the geometric boundary conditions pertaining to u_1 (at $x_2 = 0, b$) and u_2 (at $x_1 = 0, a$) are satisfied *a priori*, while those relating to u_3 , ϕ_1 and ϕ_2 are similar to their SS1 and SS2 counterparts. Partial derivatives of the assumed displacement functions, and the resulting linear algebraic equations, obtained by way of satisfying the governing PDEs (6)–(8) are identical to their SS1 counterparts, with the exception of vanishing of the constant coefficients a_m , b_m , e_n and f_n .

C4 boundary conditions

The C4 boundary condition, prescribed at all four edges, is called the Dirichlet type in the mathematical literature. The procedure for differentiation of the assumed double Fourier series solution functions for this type of boundary condition has been described in detail by Chaudhuri (1989). As in the preceding three cases, the first and second derivatives of u_3 can be obtained by term-by-term differentiation. However, the same does not hold for the second derivatives of $u_{1,11}$, $u_{2,22}$, $\phi_{1,11}$ and $\phi_{2,22}$, which are similar to their SS1 counterparts. The resulting $5mn + 2m + 2n$ linear algebraic equations, obtained by way of satisfying the governing PDEs (8)–(10) are similar to their SS4 counterparts.

4. DISCUSSION

The above procedure results in $5mn + 2m + 2n$ linear algebraic equations in terms of $5mn + 8m + 8n + 4$, $5mn + 8m + 8n + 4$, $5mn + 6m + 6n$, and $5mn + 6m + 6n$ unknowns for SS1, SS2, SS4 and C4 boundary conditions, respectively. The remaining equations are supplied by imposing the prescribed geometric and natural (whenever applicable) boundary conditions. This step will supply $6m + 6n + 4$, $6m + 6n + 4$, $4m + 4n$ and $4m + 4n$ linear algebraic equations for the SS1, SS2, SS4 and C4 boundary conditions, respectively, the details of which will be presented in the applications phase, i.e. Part II of this investigation. This procedure will finally result in systems of $5mn + 8m + 8n + 4$, $5mn + 8m + 8n + 4$, $5mn + 6m + 6n$ and $5mn + 6m + 6n$ linear algebraic equations in as many unknowns for the SS1, SS2, SS4 and C4 boundary conditions, respectively.

5. CLOSURE

A general procedure for obtaining analytical solutions to the hitherto unsolved boundary-value problems of finite general cross-ply doubly-curved panels of rectangular plan-form and subjected to transverse loads, is outlined in this paper. This method facilitates the well-posedness of the formulation through selection of the coefficients of the assumed double Fourier series solutions for the unknown functions and introduction of certain boundary-discontinuous Fourier coefficients, so that the number of equations becomes equal to the number of unknown coefficients to furnish a solution. Although the present paper discusses only three types of simply-supported and one type of clamped edge conditions, the scope of the approach presented herein is general enough to include any arbitrary type of admissible boundary conditions. Implementation of the present approach and suitable numerical examples illustrating its applicability to the four types of boundary conditions discussed herein will form the subject matter of the accompanying Part II of this investigation.

REFERENCES

- Ambartsumyan, S. A. (1953). Calculation of laminated anisotropic shells. *Izv. Akad. Nauk Armen. SSR, Ser. Fiz. Matem. Eston. Techn. Nauk* **6**, 15.
- Bert, C. W. and Kumar, M. (1982). Vibration of cylindrical shells of bimodulus composite materials. *J. Sound Vibr.* **81**, 107–121.
- Chaudhuri, R. A. (1987). A novel double Fourier series approach for solutions to boundary-value problems of moderately-thick laminated shells. Presented at *24th Annual Meet. Soc. Engng Sci.*, University of Utah, Salt Lake City.
- Chaudhuri, R. A. (1989). On boundary-discontinuous double Fourier series solution to a system of highly coupled P.D.E.s. *Int. J. Engng Sci.* **27**, 1005–1022.
- Chaudhuri, R. A. and Abu-Arja, K. R. (1988). Exact solution of shear-flexible doubly curved antisymmetric angle-ply shells. *Int. J. Engng Sci.* **26**, 587–604.
- Chaudhuri, R. A. and Abu-Arja, K. R. (1989). Closed-form solutions for arbitrarily laminated anisotropic cylindrical shells (tubes) including shear deformation. *AIAA JI* **27**, 1597–1605.
- Chaudhuri, R. A. and Kabir, H. R. H. (1987). Static and dynamic analyses of shear-flexible open cross-ply doubly curved shells. Presented (abstract published) at *24th Annual Meet. Soc. Engng Sci.*, University of Utah, Salt Lake City.
- Chia, C. Y. (1980). *Nonlinear Analysis of Plates*. McGraw-Hill, New York.
- Dong, S. B. and Tso, F. K. W. (1972). On a laminated orthotropic shell theory including transverse shear deformation. *ASME J. Appl. Mech.* **39**, 1091–1097.
- Donnell, L. H. (1933). Stability of thin walled tubes in torsion. NACA Report 479.
- Goldstein, S. (1936). The stability of viscous fluid flow under pressure between parallel planes. *Proc. Camb. Phil. Soc.* **32**, 40–49.
- Goldstein, S. (1937). The stability of viscous fluid flow between rotating cylinders. *Proc. Camb. Phil. Soc.* **33**, 41–55.
- Green, A. E. (1944). Double Fourier series and boundary value problems. *Proc. Camb. Phil. Soc.* **40**, 222–228.
- Green, A. E. and Hearmon, R. F. S. (1945). The buckling of flat rectangular plywood plates. *Phil. Mag.* **36**, 659–687.
- Greenberg, J. B. and Stavsky, Y. (1980). Buckling and vibration of orthotropic composite cylindrical shells. *Acta Mech.* **36**, 15–29.
- Hobson, E. W. (1926). *The Theory of Functions of a Real Variable and the Theory of Fourier Series*. Vol. II, Cambridge University Press, Cambridge.
- Hoff, N. J. and Rehfield, L. W. (1965). Buckling of axially compressed circular cylindrical shells at stresses smaller than the classical critical value. *ASME J. Appl. Mech.* **32**, 542–546.
- Iu, V. P. and Chia, C. Y. (1988). Nonlinear vibration and postbuckling of unsymmetric cross-ply circular cylindrical shells. *Int. J. Solids Structures* **24**, 195–210.
- Jones, R. M. and Morgan, H. S. (1975). Buckling and vibration of cross-ply laminated circular cylindrical shells. *AIAA JI* **13**, 664–671.
- Khdeir, A. A., Librescu, L. and Frederick, D. (1989). A shear deformable theory of laminated composite shallow shell-type panels and their response analysis II: Static response. *Acta Mech.* **77**, 1–12.
- Librescu, L., Khdeir, A. A. and Frederick, D. (1989). A shear deformable theory of laminated composite shallow shell-type panels and their response analysis I: Free vibration and buckling. *Acta Mech.* **76**, 1–12.
- Love, A. E. H. (1927). *A Treatise on the Mathematical Theory of Elasticity* (4th Edn). Cambridge University Press, Cambridge.
- Morley, L. S. D. (1959). An improvement of Donnell's approximation of thin-walled circular cylinders. *Q. J. Mech. Appl. Math.* **8**, 89–99.
- Sanders, J. L., Jr (1959). An improved first-approximation theory for thin shells. NASA Tech. Rept., R-24.
- Sinha, P. K. and Rath, A. K. (1976). Transverse bending of cross-ply laminated circular cylindrical plates. *J. Mech. Engng Sci.* **18**, 53–56.
- Soldatos, K. P. (1984a). A comparison of some shell theories used for the dynamic analysis of cross-ply laminated circular cylindrical panels. *J. Sound Vibr.* **97**, 305–319.

- Soldatos, K. P. (1984b). A Flugge type theory for the analysis of anisotropic laminated non-circular cylindrical shells. *Int. J. Solids Structures* **20**, 107–120.
- Soldatos, K. P. and Tzivandis, G. J. (1982). Buckling and vibration of cross-ply laminated circular cylindrical panels. *J. Appl. Math. Phys. (ZAMP)* **33**, 230–239.
- Stavsky, Y. and Lowey, R. (1971). On vibrations of heterogeneous orthotropic cylindrical shells. *J. Sound Vibr.* **15**, 235–256.
- Whitney, J. M. (1970). The effect of boundary conditions on the response of laminated composites. *J. Compos. Mater.* **4**, 192–203.
- Whitney, J. M. (1971). Fourier analysis of clamped anisotropic plates. *ASME J. Appl. Mech.* **38**, 530–532.
- Whitney, J. M. and Leissa, A. W. (1970). Analysis of a simply supported laminated anisotropic rectangular plate. *AIAA J* **8**, 28–33.
- Winslow, A. M. (1951). Differentiation of Fourier series in stress solutions for rectangular plates. *Q. J. Mech. Appl. Math.* **4**, 449–460.

APPENDIX A

The differentiation of full-range double Fourier series

For the purpose of illustrating the approach, $u_1(x_1, x_2)$, which, as defined in eqns (11), is an even function with respect to x_1 , and an odd function with respect to x_2 , is considered:

$$u_1(x_1, -x_2) = -u_1(x_1, x_2) = -u_1(-x_1, x_2). \quad (\text{A1})$$

The full-range double Fourier series expansion for the function and its two first partial derivatives are as follows:

$$u_1(x_1, x_2) = \sum_{m=0}^{\infty} \sum_{n=1}^{\infty} U_{mn} \cos(\alpha_m x_1) \sin(\beta_n x_2), \quad (\text{A2a})$$

$$u_{1,1}(x_1, x_2) = \sum_{m=1}^{\infty} \sum_{n=1}^{\infty} B_{mn} \sin(\alpha_m x_1) \sin(\beta_n x_2), \quad (\text{A2b})$$

$$u_{1,2}(x_1, x_2) = \sum_{m=0}^{\infty} \sum_{n=0}^{\infty} C_{mn} \cos(\alpha_m x_1) \cos(\beta_n x_2), \quad (\text{A2c})$$

wherein

$$U_{mn} = \frac{1}{ab} \int_{-a}^a \int_{-b}^b u_1(x_1, x_2) \cos(\alpha_m x_1) \sin(\beta_n x_2) dx_1 dx_2, \quad \text{for } m, n = 1, 2, \dots, \infty. \quad (\text{A3})$$

U_{0n} , B_{mn} , C_{mn} , C_{0n} , C_{m0} and C_{00} can be similarly defined. Integration by parts of the right-hand side of eqn (A3) yields the following:

$$B_{mn} = -\alpha_m U_{mn} + \frac{1}{ab} \int_{-b}^b \left[\sum_{d=1}^{d^{(N_1)}} \{u_1(x_{1d}-0, x_2) - u_1(x_{1d}+0, x_2)\} \sin(\alpha_m x_{1d}) \right] \sin(\beta_n x_2) dx_2, \quad \text{for } m, n = 1, 2, \dots, \infty, \quad (\text{A4a})$$

$$C_{mn} = \beta_n U_{mn} + \frac{1}{ab} \int_{-a}^a \{u_1(x_1, b-0) - u_1(x_1, -b+0)\} (-1)^n \cos(\alpha_m x_1) dx_1 + \frac{1}{ab} \int_{-a}^a \sum_{d=1}^{d^{(N_2)}} \{u_1(x_1, x_{2d}-0) - u_1(x_1, x_{2d}+0)\} \sin(\beta_n x_{2d}) \cos(\alpha_m x_1) dx_1, \quad \text{for } m, n = 1, \dots, \infty. \quad (\text{A4b})$$

Similar expressions can be obtained for C_{0n} , C_{m0} and C_{00} . $x_1 = x_{1d}$ and $x_2 = x_{2d}$ in eqns (A4a, b) represent lines of discontinuities, while $d^{(N_i)}$, $i = 1, 2$, denotes the number of discontinuities in the x_i direction.

Differentiation of half-range double Fourier series

The present solution, e.g. $u_1(x_1, x_2)$, given by eqns (15) is represented by a double Fourier series in the domain $(0, a) \times (0, b)$, the lengths of the intervals in the directions x_1 and x_2 being one-half of the full ranges of intervals of periodicity $2a$ and $2b$, respectively. $u_1(x_1, x_2)$, in addition to being an even function of x_1 and an odd function of x_2 as stated earlier, is also continuous in the interior of the domain $(0, a) \times (0, b)$, and does not vanish at the edges, $x_2 = 0, b$. Substitution of

$$d^{(N_1)} = 1, \quad x_{1d} = 0, \quad u_1(0-0, x_2) = u_1(0+0, x_2) \quad (\text{A5})$$

into eqn (A4a) yields

$$B_{mn} = -\alpha_m U_{mn}, \quad (\text{A6})$$

which implies that the first partial derivative, $u_{1,1}(x_1, x_2)$, can be obtained by termwise differentiation of the half-range Fourier series expansion of $u_1(x_1, x_2)$. However, the other first partial derivative, $u_{1,2}(x_1, x_2)$, cannot be represented by the termwise differentiation of the series, because $u_{1,2}(x_1, x_2)$ has ordinary discontinuity at the line $x_2 = 0$ and also because

$$u_1(x_1, b-0) \neq u_1(x_1, -b+0) \neq 0. \quad (\text{A7})$$

The Fourier coefficients for $u_{1,2}(x_1, x_2)$ must then be obtained by substituting in eqns (A4)

$$d^{(N2)} = 1, \quad x_{2d} = 0 \quad \text{and} \quad u_1(x_1, -b+0) = -u_1(x_1, b-0), \quad u_1(x_1, 0-0) = -u_1(x_1, 0+0) \quad (\text{A8})$$

which finally yields

$$C_{mn} = \beta_n U_{mn} + \frac{4}{ab} \int_0^a \{u_1(x_1, b-0)(-1)^n - u_1(x_1, 0+0)\} \cos(\alpha_m x_1) dx_1, \quad \text{for } m, n = 1, 2, \dots, \infty. \quad (\text{A9})$$

Similar expressions can be obtained for C_{0n} , C_{m0} and C_{00} [see Chaudhuri (1989)].

APPENDIX B

The unknown Fourier coefficients, arising from discontinuities [in the sense of Hobson (1926)] at the edges, are defined as follows:

$$(a_m, b_m) = \frac{4}{ab} \int_0^a [\pm u_1(x_1, b) - u_1(x_1, 0)] \cos(\alpha_m x_1) dx_1, \quad (\text{B1a})$$

$$(c_n, d_n) = \frac{4}{ab} \int_0^b [\pm u_{1,1}(a, x_2) - u_{1,1}(0, x_2)] \sin(\beta_n x_2) dx_2, \quad (\text{B1b})$$

$$(e_n, f_n) = \frac{4}{ab} \int_0^b [\pm u_2(a, x_2) - u_2(0, x_2)] \cos(\beta_n x_2) dx_2, \quad (\text{B1c})$$

$$(g_m, h_m) = \frac{4}{ab} \int_0^a [\pm u_{2,2}(x_1, b) - u_{2,2}(x_1, 0)] \sin(\alpha_m x_1) dx_1, \quad (\text{B1d})$$

$$(i_n, j_n) = \frac{4}{ab} \int_0^b [\pm \phi_{1,1}(a, x_2) - \phi_{1,1}(0, x_2)] \sin(\beta_n x_2) dx_2, \quad (\text{B1e})$$

$$(k_m, l_m) = \frac{4}{ab} \int_0^a [\pm \phi_{2,2}(x_1, b) - \phi_{2,2}(x_1, 0)] \sin(\alpha_m x_1) dx_1. \quad (\text{B1f})$$

APPENDIX C

The nonzero constants $G(i, j)$; $i = 1, 5$ and $j = 1, 2, \dots$, referred to in eqn (8) are as given below:

$$G(1, 1) = -\frac{A_{55}}{R_1^2}, \quad G(1, 2) = A_{11}, \quad G(1, 3) = A_{66} + 2cB_{66} + c^2D_{66},$$

$$G(1, 4) = A_{12} + A_{66} - c^2D_{66}, \quad G(1, 5) = \frac{A_{11}}{R_1} + \frac{A_{12}}{R_2} + \frac{A_{55}}{R_1}, \quad G(1, 6) = \frac{A_{55}}{R_1},$$

$$G(1, 7) = B_{11}, \quad G(1, 8) = B_{66} + cD_{66}, \quad G(1, 9) = B_{12} + B_{66} + cD_{66}, \quad (\text{C1a})$$

$$G(2, 1) = G(1, 4), \quad G(2, 2) = -\frac{A_{44}}{R_2^2}, \quad G(2, 3) = A_{66} - 2cB_{66} + c^2D_{66},$$

$$G(2, 4) = A_{22}, \quad G(2, 5) = \frac{A_{12}}{R_1} + \frac{A_{22}}{R_2} + \frac{A_{44}}{R_2}, \quad G(2, 6) = B_{12} + B_{66} - cD_{66},$$

$$G(2, 7) = \frac{A_{44}}{R_2}, \quad G(2, 8) = B_{66} - cD_{66}, \quad G(2, 9) = B_{22}, \quad (\text{C1b})$$

$$G(3, 1) = -G(1, 5), \quad G(3, 2) = -G(2, 5), \quad G(3, 3) = -\left(\frac{A_{11}}{R_1^2} + \frac{2A_{12}}{R_1 R_2} + \frac{A_{22}}{R_2^2}\right),$$

$$G(3, 4) = A_{55}, \quad G(3, 5) = A_{44}, \quad G(3, 6) = A_{55} - \frac{B_{11}}{R_1} - \frac{B_{12}}{R_2},$$

$$G(3, 7) = A_{44} - \frac{B_{12}}{R_1} - \frac{B_{22}}{R_2}, \quad (\text{C1c})$$

$$G(4, 1) = G(1, 6), \quad G(4, 2) = B_{11}, \quad G(4, 3) = B_{66} + cD_{66},$$

$$G(4, 4) = G(2, 6), \quad G(4, 5) = -G(3, 6), \quad G(4, 6) = -A_{55},$$

$$G(4, 7) = D_{11}, \quad G(4, 8) = D_{66}, \quad G(4, 9) = D_{12} + D_{66}, \quad (\text{C1d})$$

$$G(5, 1) = B_{66} + B_{12} + cD_{66}, \quad G(5, 2) = \frac{A_{44}}{R_2}, \quad G(5, 3) = G(2, 8), \quad G(5, 4) = B_{22},$$

$$G(5, 5) = -G(3, 7), \quad G(5, 6) = G(4, 9), \quad G(5, 7) = -A_{44}, \quad G(5, 8) = D_{66}, \quad G(5, 9) = D_{22}. \quad (\text{C1e})$$